



Version with  
NPT thread

Version  
with plastic  
cable gland



## Design

The housing is manufactured entirely of thermoplastic, thereby ensuring a high level of protection against corrosion. Potential equalisation conductor is only use for protection class I.

Explosion protection is guaranteed, among other things, by the terminal box of the "increased safety" protection type.

The transformer module is encapsulated by means of a sealing compound, making it gas-tight.

## Application

The STARLINE range of loudspeakers was designed not only for acoustic signalling and emergency communications but also for speech transmission under rugged environmental conditions in potentially explosive areas of group II. The protection degree allows the loudspeaker to be used in the hazardous areas of zones 1 and 2 as well as zones 21 and 22. In addition, further models will be in the weatherproof application IP 66 available.

## Explosionproof loudspeaker for use in hazardous zones and weatherproof loudspeaker for acoustic signalling and emergency communications

### EEx II Loudspeaker Zone 1 + 2 + 21 + 22

- ▶ STAR 2500
- ▶ STAR 1500

### Weatherproof Loudspeaker

- ▶ STAR W25
- ▶ STAR W15





# Type overview

## Technical Data

### Dimensions

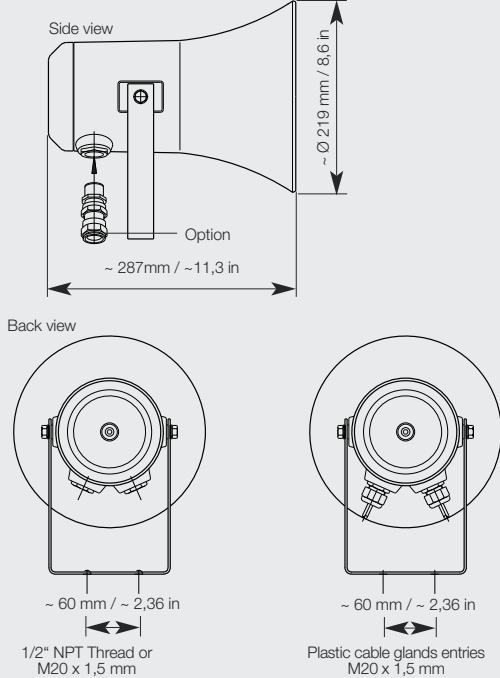

Housing	Plastic, UV-resistant
Colour	Black or red
Stirrup-type mounting bracket, cover screw	Stainless steel V4A (ASTM 316)
Cable entry	Depending on type (M20 or 1/2")
Connection terminals	up to 2.5 mm <sup>2</sup> (AWG 14) fine wire up to 2.5 mm <sup>2</sup> single wire
Min./max. temperature range	T4 -55°C to + 80°C T5 -55°C to + 65°C T6 -55°C to + 55°C
STAR 2500 UL	-20°C to + 55°C
Protection degree	IP 66 IEC 60529
Supply voltage	100 V
Max. power	Depending on type (25 W or 15 W)
Power stages via coding	25 W; 12.5 W; 8 W; 4 W; 2 W; 1 W 15 W; 8 W; 4 W; 2 W
Volume	approx. 119 dB(A) 25 W approx. 118 dB(A) 15 W
Transmission range	230 – max. 10000 Hz
Transmission range acc. to IEC 60268	330 – 6200 Hz
Angle of radiation 1 kHz–6 dB	130°
Angle of radiation 4 kHz–6 dB	40°
Protection categories	CE 0158 II 2 G Ex demb IIC T *) II 3 G Ex nAnC IIC T *) IP66 CE 0158 II 2 D Ex tD A21 T80°C, T95°C, T130°C **) II 3 D Ex tD A22 IP66 T80°C, T95°C, T130°C **)
Operating temperature	*) T4 -55°C ≤ Tamb ≤ +80°C *) T5 -55°C ≤ Tamb ≤ +65°C *) T6 -55°C ≤ Tamb ≤ +55°C **) -55°C ≤ Tamb ≤ +55°C, +65°C, +80°C

\* These are the guaranteed upper power limits with regard to flameproof conditions, manufacturing tolerances, operating temperature and control below the transmission range. The typical electric power consumption within the transmission range is 8 W or 12 W (depending on version).

## Order information

Type	Approved	Design	Housing-Colour	Approval Certificate	Approval	Art.-No.
StarLine 15 W	zone 1,2,21,22	Plastic KLE M20 x 1.5	black	II 2 GD..	ATEX	12393701
StarLine 15 W	zone 1,2,21,22	Adapter M20 x 1.5	black	II 2 GD..	ATEX	12393907
StarLine 15 W	zone 1,2,21,22	Adapter 1/2 NPT	black	II 2 GD..	ATEX	12393807
StarLine 25 W	zone 1,2,21,22	Plastic KLE M20 x 1.5	black	II 2 GD..	ATEX	12383701
StarLine 25 W	zone 1,2,21,22	Adapter M20 x 1.5	black	II 2 GD..	ATEX	12383907
StarLine 25 W	zone 1,2,21,22	Adapter 1/2 NPT	black	II 2 GD..	ATEX	12383807
StarLine 25 W	zone 1	Plastic KLE M20 x 1.5	black	II 2 GD..	GOST	1238370150
StarLine 25 W	class 1	Adapter 1/2 NPT	black	Division 2	UL	12383801
StarLine 15 W	zone 1,2,21,22	Plastic KLE M20 x 1.5	red	II 2 GD..	ATEX	1239370110
StarLine 15 W	zone 1,2,21,22	Adapter M20 x 1.5	red	II 2 GD..	ATEX	1239390710
StarLine 15 W	zone 1,2,21,22	Adapter 1/2 NPT	red	II 2 GD..	ATEX	1239380710
StarLine 25 W	zone 1,2,21,22	Plastic KLE M20 x 1.5	red	II 2 GD..	ATEX	12393701
StarLine 25 W	zone 1,2,21,22	Adapter M20 x 1.5	red	II 2 GD..	ATEX	12393907
StarLine 25 W	zone 1,2,21,22	Adapter 1/2 NPT	red	II 2 GD..	ATEX	12393807
STAR W25	-	Plastic KLE M20 x 1.5	black	-	-	12983701
STAR W15	-	Plastic KLE M20 x 1.5	black	-	-	12993701

Subject to change without notice · Printout 06/10