

Strobe Light BLG 10

Compact strobe light with solid rubber housing for vibration-proof mounting

- ▶ Flash energy 10 Joule
- ▶ Vibration-proof housing
- ▶ Protection degree IP 67
- ▶ Protection class II



Application

It is often necessary to use optical signals for warning, indicating and signalling purposes in areas where vibrations may occur.

Such areas are machines, vehicles, cranes, and so on. The Strobe Light BLG 10 provides this signalling capacity with a flash energy of 10 Joule.

The Strobe Light BLG 10 is activated by turning on the supply voltage. It is available in various cap colours. The solid rubber housing conforms to protection degree IP 67 and is suitable for both indoor and outdoor use.

Design

The housing is made of solid rubber (elastic TPF). The cap consists of impact polycarbonate.

A high performance Xenon flash tube very efficiently converts the electric energy stored in the flash condenser to light flashes.

Alarm indication at a machine

It is often necessary to use signals for warning purposes in areas where vibrations may occur.



Technical Data

Housing	Elastic TPF, cap polycarbonate
Colour	Black
Protection degree	IP 67 (IEC 529)
Protection class	II (no external equipotential bonding necessary)
Cable gland reducer	6–8 mm, rubber sealing without tensile strength
Connecting terminals	1.5 mm ² fine-wired
Operating conditions	Inside or outside
Operating position	Cable entry downwards
Operating mode	Continuous
Temperature range	
Operating	-20°C to +50°C
Storage	-30°C to +70°C
Weight	Approx. 0.45 kg

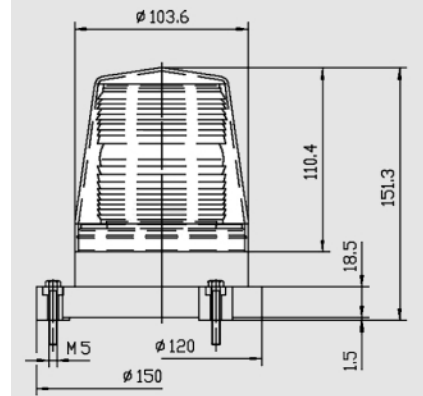

Order information

* The full article number is made up by appending the colour code for the coloured cap to the article numbers given below.

transp.	01
red	02
amber	03
green	04
blue	05

Type	Name	Rated voltage U _e	Tolerance U _e	Current consumption	Art. no.
BLG 10	Strobe light	230 VAC	+10/-15%	0,08 A	224 607 ..
BLG 10	Strobe light	115 VAC	+10/-15%	0,16 A	224 606 ..
BLG 10	Strobe light	24 VAC/DC	10-100 VDC 20- 75 VAC	0,05 - 0,16 A 0,10 - 0,16 A	224 613 ..

Subject to change without notice · Printout 08/07