



# Sounder

## EV 21 and EV 24

**Compact, all-purpose signalling device for indoor and outdoor use**

- ▶ 21 different signal tones, adjustable
- ▶ Emergency signal acc. to DIN 33404/3
- ▶ Volume: approx. 105 dB(A)
- ▶ For DC and AC voltage supplies
- ▶ Version with tamper contact for security systems
- ▶ 24 VDC with  $\leq 500$  mA inrush-current limitation for use with PLC
- ▶ VdS-approval for automatic fire alarm systems (24 VDC) in preparation
- ▶ Type EV 24 for extended temperature range **-50° C to +60° C**

2

### Application

The EV 21 (EV 24) signalling device is an electronic sounder for indoor and outdoor use. Thanks to its sturdy construction, the device can even be used in difficult environmental conditions. It generates 21 different signal tones digitally. The signal tones are set by the user. The signals are grouped in threes and can either be set individually in the device or adjusted and controlled externally via potential-free contacts.

### Design

The device is a very compact unit comprising power supply, microprocessor, amplifier and loudspeaker. The housing is made of seawater-proof cast aluminium and coated in plastic. The loudspeaker is made of impact and cold-resistant plastic and is mounted firmly on the housing.

### Emergency equipment on a car park deck

The EV 21 (EV 24) generates 21 different signal tones digitally.



## Technical specifications

Housing	Seawater-proof aluminium	
Colour	Light grey	
Protection degree	IP 54 (IEC 529)	
Protection class	I	
Cable gland	1 x Pg 11 for cables 8–11 mm (second cable gland is retrofittable)	
Connection terminals	Cross section: 2.5 mm <sup>2</sup> single wire 1.5 mm <sup>2</sup> fine wire	
Operating conditions	Indoors and outdoors	
Operating position	Preferably horizontal, cable gland downwards	
Operating mode	Continuous	
<b>Volume</b>	Max. 105 dB(A), 1 m (Regarding volume specifications, please see the chapter "Technical Informations".)	
Loudspeaker	Dynamic pressure-chamber loudspeaker, impact-resistant plastic (ABS); firmly mounted on the housing	
Signals	21 tones adjustable by switch Selection of 3 tones, also adjustable externally Tone 1 Emergency signal acc. to DIN 33404 Tone 2 Hooter signal Factory setting Tone 3 4-tone gong	
Temperature range	EV 21	EV 24
Operation	-25 °C to +60 °C	-50 °C to +60 °C
Storage	-30 °C to +70 °C	-50 °C to +70 °C
Weight	Approx. 1.7 kg	

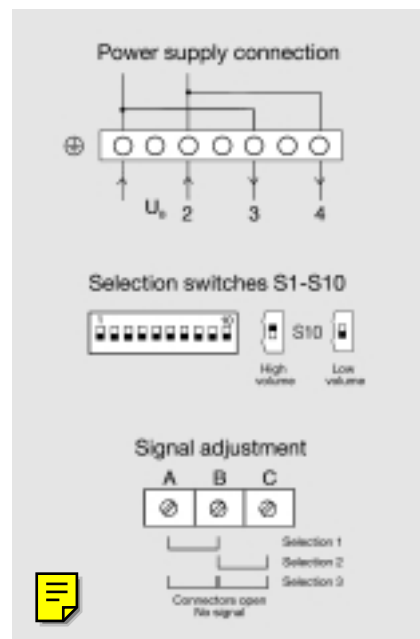
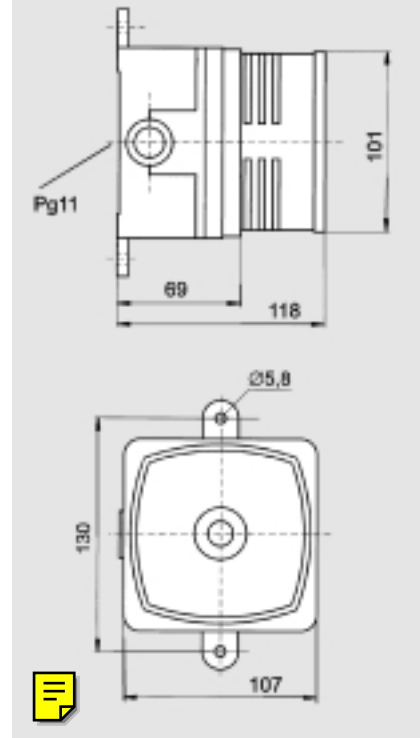

## Order information

Type	Name	Rated voltage U <sub>B</sub>	Operating voltage range U <sub>B</sub>	Current consumption	Fuse 5 x 20	Article no.
EV 21	Sounder	12/24 VAC 50–60 Hz	10–25 V	0.16 A	T 1.25 / 250 C	215 612 01
EV 21 D	Sounder	12/24 VAC 50–60 Hz	10–25 V	0.16 A	T 1.25 / 250 C	215 612 10
EV 21	Sounder	12/24 VDC	10–30 V	0.16 A	T 1.25 / 250 C	215 612 01
EV 21 D	Sounder	12/24 VDC	10–30 V	0.16 A	T 1.25 / 250 C	215 612 10
EV 21	Sounder	110 VAC 50–60 Hz	+15/-15 %	0.06 A	M 0.1 / 250 C	215 612 02
EV 21	Sounder	230 VAC 50–60 Hz	+10/-15 %	0.03 A	M 0.1 / 250 C	215 612 03
EV 24	Sounder	12/24 VDC	10–30 V	0.16 A	T 1.25 / 250 C	215 615 01
EV 24	Sounder	230 VAC 50–60 Hz	+10/-15%	0.03 A	M 0.1 / 250 C	215 615 03

T = time lag / M = medium time lag

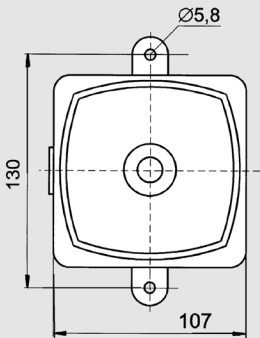
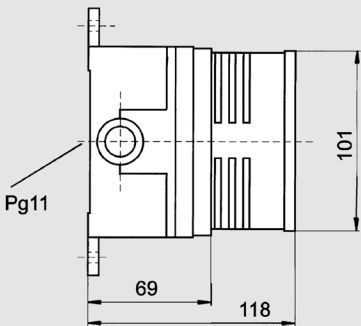

## Power supply connection

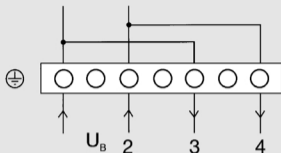

## Selection switches S1-S10



## Signal adjustment



Selection 1

Selection 2

Selection 3

Connectors open  
No signal

# Sounder EV 21 (EV 24)

Table 1

## Signals

Tone 1: Emergency signal acc. to DIN 33404/EN457 T3  
Descending signal 1200/500 Hz/1 Hz

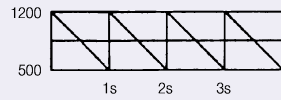

Tone 2: Hooter signal  
720 Hz/700 ms on // 0 Hz/300 ms off

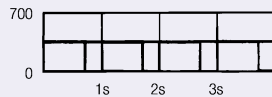

Tone 3: 4-tone gong  
660 Hz/1.2 s + 550 Hz/1.2 s + 440 Hz/1.2 s + 330 Hz/1.6 s + 0.7 s break

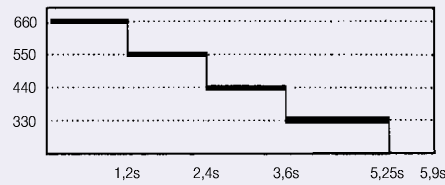

Tone 4: Continuous signal  
Frequency adjustable in 50 Hz steps  
between 300 Hz and 1850 Hz

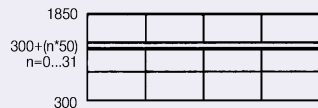

Tone 5: Descending signal 1300/700 Hz//0.5 Hz



Tone 6: Descending signal 800/500 Hz//0.7 Hz

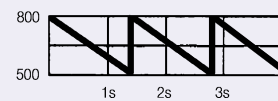

Tone 7: Increasing signal 500/800 Hz//0.7 Hz

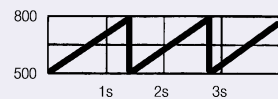

Tone 8: Wail 450/650 Hz//2 Hz

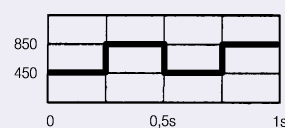

Tone 9: Hooter signal 650/0 Hz//2 Hz

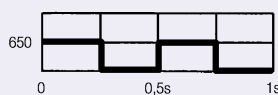

Tone 10: Siren signal 270/500 Hz//1 Hz

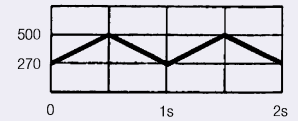

Tone 11: Siren signal 800/970 Hz//1 Hz

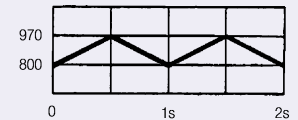

Tone 12: Siren signal 2400/2850 Hz//7 Hz

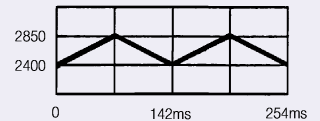

Tone 13: Siren signal 2400/2850 Hz//1 Hz

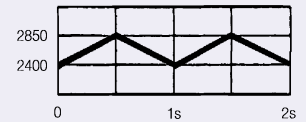

Tone 14: Wail 2400/2850 Hz//2 Hz

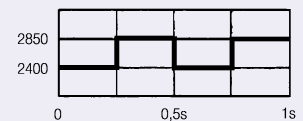

Tone 15: Hooter signal 970/0 Hz//2 Hz

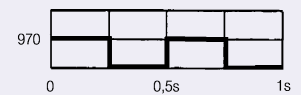

Tone 16: Hooter signal 660/0 Hz//3,3 Hz

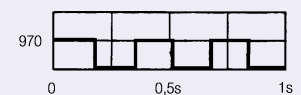

Tone 17: Siren signal 700/1300 Hz//0,5 Hz

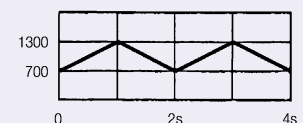

Tone 18: Siren signal 700/1300 Hz//1 Hz

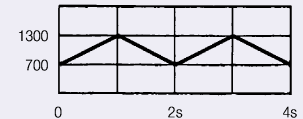

Tone 19: ISO 8201 EVACUATION 970/0 Hz

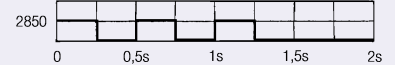

Tone 20: ISO 8201 EVACUATION 2850/0 Hz

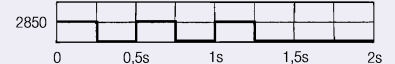

Tone 21: American Patrol Dip switch

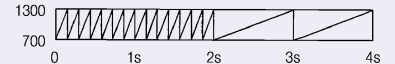

# Sounder EV 21 (EV 24)

	Dip switch: 1-4	A - B Selection 1	B - C Selection 2	A B C Selection 3
0		Tone 1	Tone 2	Tone 3
1		Tone 1	Tone 2	Tone 4
2		Tone 1	Tone 2	Tone 5
3		Tone 1	Tone 3	Tone 4
4		Tone 1	Tone 3	Tone 5
5		Tone 1	Tone 4	Tone 5
6		Tone 2	Tone 3	Tone 4
7		Tone 2	Tone 3	Tone 5

	Dip switch: 1-4	A - B Selection 1	B - C Selection 2	A B C Selection 3
8		Tone 2	Tone 4	Tone 5
9		Tone 3	Tone 4	Tone 5
10		Tone 1	Tone 2	Tone 6-21 Selection with S5-S9
11		Tone 1	Tone 3	Tone 6-21 Selection with S5-S9
12		Tone 1	Tone 6-21 Selection with S5-S9	Tone 5
13		Tone 2	Tone 3	Tone 6-21 Selection with S5-S9
14		Tone 2	Tone 6-21 Selection with S5-S9	Tone 5
15		Tone 3	Tone 6-21 Selection with S5-S9	Tone 5

	Dip switch: 5-9	Tone	Continuous signal (Ton 4)
1		Tone 6	300 Hz
2		Tone 7	350 Hz
3		Tone 8	400 Hz
4		Tone 9	450 Hz
5		Tone 10	500 Hz
6		Tone 11	550 Hz
7		Tone 12	600 Hz
8		Tone 13	650 Hz
9		Tone 14	700 Hz
10		Tone 15	750 Hz
11		Tone 16	800 Hz
12		Tone 17	850 Hz
13		Tone 18	900 Hz
14		Tone 19	950 Hz
15		Tone 20	1000 Hz
16		Tone 21	1050 Hz

	Dip switch: 5-9	Tone	Continuous signal (Ton 4)
17		Tone 6	1100 Hz
18		Tone 7	1150 Hz
19		Tone 8	1200 Hz
20		Tone 9	1250 Hz
21		Tone 10	1300 Hz
22		Tone 11	1350 Hz
23		Tone 12	1400 Hz
24		Tone 13	1450 Hz
25		Tone 14	1500 Hz
26		Tone 15	1550 Hz
27		Tone 16	1600 Hz
28		Tone 17	1650 Hz
29		Tone 18	1700 Hz
30		Tone 19	1750 Hz
31		Tone 20	1800 Hz
32		Tone 21	1850 Hz

