

Exploline



Ex-Signalling Hooter dGH 21 / dRGH 21

Modular concept with GRP housing for use in areas with explosive atmospheres in zone 1 and 2

- ▶ ATEX II 2 G Ex de IIC T5 / T6
- ▶ Housing made of glass-fibre reinforced polyester (GRP)
- ▶ Volume: approx. 105 dB(A)
- ▶ Protection degree IP 66
- ▶ Protection class II (no equipotential bonding necessary)
- ▶ Version dRGH 21 with integrated telephone call relay
- ▶ Integrated terminal box realized in Ex protection mode increased safety



Application

The Ex-Signalling hooter dGH21 was developed for warning, calling and indicating purposes in areas with explosive atmospheres in group II and for rough ambient conditions. Thanks to its compliance with the explosion protection class II 2 G Ex de IIC T5/T6, this signalling device can be used without restriction in all areas with explosive atmospheres in zones 1 and 2. The signalling hooter produces a sound volume of approx. 105dB(A) at 1 meter distance. The characteristic hooting sound can be clearly heard above any other higher-frequency sounds in the area. The dRGH21 comprises a telephone calling relay and reproduces the signals in the pulse rate of the overriding telephone call.

Design

The explosion protection is given through the flameproof chamber and the chamber "increased safety". The flameproof chamber contains the electromagnetic drive system and, for the dRGH21, an additional telephone calling relay. The signal membrane is mounted outside of the flameproof room beneath a closing cap with the appropriate sound control. The housing is made of GRP thus guaranteeing protection against corrosion. Furthermore the construction is low-weight and highly robust. All DC versions are equipped with an electronic contact breaker which considerably increases service life compared with other commercially available devices.

Emergency Signal in a chemical plant

The Ex-Signalling hooter dGH21 was developed for warning in areas with explosive atmospheres.



Technical specification

Housing	GRP glass-fibre reinforced polyester Colour: black or red	
Protection degree	IP 66 (acc. IEC529)	
Protection class	II (no equipotential bonding necessary)	
Cable gland	1x M20 x 1.5 cable gland and 1 blind plug M20 x 1.5 dRGH21: 2x M20 x 1.5 cable glands	
Connection terminals	1.5 mm ² fine wire; 2.5 mm ² single wire	
Operating conditions	indoors and outdoors	
Operating position	preferably sound exit to the front	
Volume	approx. 105dB(A) at 1m distance (Regarding volume specifications please see the chapter "Technical Informations")	
Operating mode	Continuous	
Temperature range		
Operation	-20°C to +70°C (T6)	-20°C to +75°C (T5)
Storage	-20°C to +80°C	
Explosion Protection	II 2 G Ex de IIC T5 / T6	
Weight	ca. 5.5 kg	

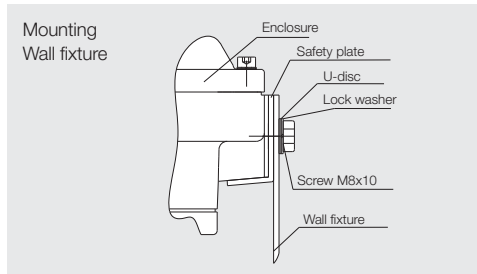
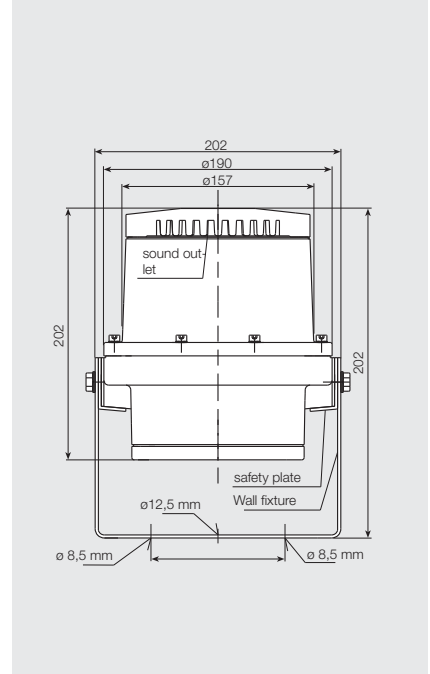

Terminal onnection plan

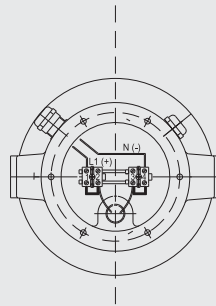

for dRGH 21

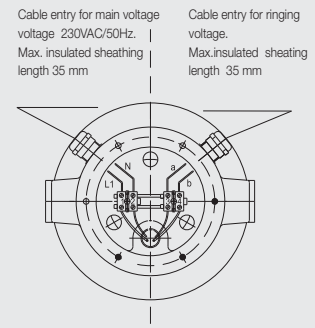

Order information

*All article-numbers are ATEX-variants

Type	Name	Rated Voltage U _e	Oper. Volt. range U _e	Current Cons.	Article no.
Housing red					
dGH 21	Ex-Signalling Hooter	12 VDC	+10/-15%	0,6 A	9201221013*
dGH 21	Ex-Signalling Hooter	24 VAC	+10/-15%	0,65 A	9202411013*
dGH 21	Ex-Signalling Hooter	24 VDC	+10/-15%	0,3 A	9202421013*
dGH 21	Ex-Signalling Hooter	110 VDC	+10/-15%	0,08 A	9211021013*
dGH 21	Ex-Signalling Hooter	120 VAC 60 Hz	+10/-15%	0,15 A	9212011013*
dGH 21	Ex-Signalling Hooter	230 VAC	+10/-15%	0,07 A	9223011013*
dRGH 21	Ex-Signalling Hooter	230 VAC <small>with telephone call relay</small>	+10/-15%	0,07 A	9223011010*
dGH 21	Ex-Signalling Hooter	240 VAC 60 Hz	+10/-15%	0,07 A	9224011013*
Housing black					
dGH 21	Ex-Signalling Hooter	12 VDC	+10/-15%	0,6 A	92012210*
dGH 21	Ex-Signalling Hooter	24 VAC	+10/-15%	0,65 A	92024110*
dGH 21	Ex-Signalling Hooter	24 VDC	+10/-15%	0,3 A	92024210*
dGH 21	Ex-Signalling Hooter	110 VDC	+10/-15%	0,08 A	92110210*
dGH 21	Ex-Signalling Hooter	120 VAC 60 Hz	+10/-15%	0,15 A	92120110*
dGH 21	Ex-Signalling Hooter	230 VAC	+10/-15%	0,07 A	92230110*
dRGH 21	Ex-Signalling Hooter	230 VAC <small>with telephone call relay</small>	+10/-15%	0,07 A	9223011000*
dGH 21	Ex-Signalling Hooter	240 VAC 60 Hz	+10/-15%	0,07 A	9224011060*

Other voltages on request

Subject to change without notice · Printout 12/09